



PHTY



PHGY

本體	固體潤滑劑
材質	材質
FC250(鑄鐵)	MoS <sub>2</sub>

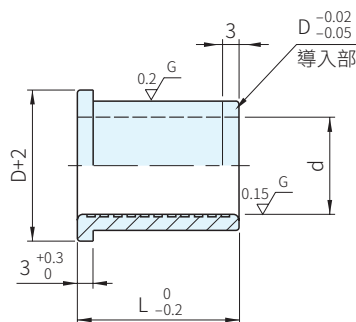
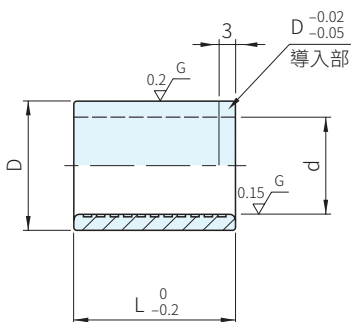

品號		L							D	
TYPE	d	10	13	16	20	25	30	35		
PHTY	8	·	·	·	·				13	0 -0.005
	10	·	·	·	·	·			16	
	13		·	·	·	·	·		20	
	16		·	·	·	·	·	·	24	0 -0.006
	20				·	·	·	·	28	0 -0.007
	25				·	·	△	△	34	

品號		L							D	
TYPE	d	10	13	16	20	25	30	35		
PHGY	8	·	·	·	·				13	0 -0.005
	10	·	·	·	·	·			16	
	13		·	·	·	·	·		20	
	16		·	·	·	·	·	·	24	0 -0.006
	20				·	·	·	·	28	0 -0.007
	25				·	·	△	△	34	

**WA. 注意**

- PHTD, PHTG和PHSG, PHUG, PHSM, PHUM, PHSQ, PHUQ配合使用
- 適當的給油, 導柱導套壽命更佳
- 以輕滑配或厭氧膠(LOC680, LOC638)黏著固定
- 高速導柱、導套、滾珠套專用之有機鉬強力潤滑劑請參考 S-00668

訂貨：  ×  交期：  天 ·  天 △  
PHTY10 × 10